



For more information, use your smartphone's QR reader to find out more about the Exiss lineup.

1 (877) 553-9477 | 900 E. Trail Blvd. | El Reno, OK 73036 | www.exiss.com | sales@exiss.com

In keeping with its policy of continuous improvement, Exiss reserves the right to make specification changes at any time without notice or obligation. All dimensions listed in this brochure are approximate. Illustrations may include optional equipment.

© 2011 Exiss | Version 11.9



LOW PROFILE LIVESTOCK



1 (877) 553-9477 // www.exiss.com // sales@exiss.com

 BY UNIVERSAL TRAILER

LOW PROFILE



Perfect for hauling smaller livestock, the Exiss low profile trailers can be equipped to haul swine, goats, miniature horses and other small animals. With a broad lineup of standard features, Exiss low profile trailers are the safest way to transport your smaller stock. Exiss' unparalleled options and customizations mean you can haul a rig tailored just for you. Whether you're looking for an easy-to-use bumper pull or a rugged gooseneck, Exiss has the low profile trailer you need.



BUMPER PULL

7' Wide Models



TRAILER FEATURES

STANDARD FEATURES

- Available in 14' and 18' models
- 6' inside height - 7' outside width
- All-aluminum construction
- Single piece aluminum roof
- Gravel guard across nose
- Full length, polished aluminum extruded sides
- Three air gaps and Plexiglas
- Interlocking extruded aluminum plank non-skid floor
- Floor system features 2" X 4" I-beams on 13" centers
- Two 3,500 lbs rubber torsion axles
- Five 15" aluminum wheels with five radial tires
- Two LED tail lights and one large LED clearance light
- 50/50 rear doors with one window per door
- Locking cam latches on livestock area doors

LIVESTOCK AREA FEATURES

- Multiple 4' long pens with divider gates on each side
- Pens convert from 'Alley Way' to '50/50' configuration
- Heavy-duty curbside escape door
- Tray in livestock area for Plexiglas storage
- Dome lights with switch recessed in rear frame

DRESSING ROOM FEATURES

- Carpeted dressing room area with 4' straightwall
- One dome light in dressing room
- Clothes rod

POPULAR OPTIONS

- 36" removable shelf in livestock area (14" deep)
- Aluminum pop-up roof vents in livestock area
- Center gate (with or without slider)
- Full width rear ramp
- 24" walk through door in solid wall
- Built in storage rack for feed pans
- Built in storage bin for whips
- Fold-up step below camper door



TRAILER SPECIFICATIONS

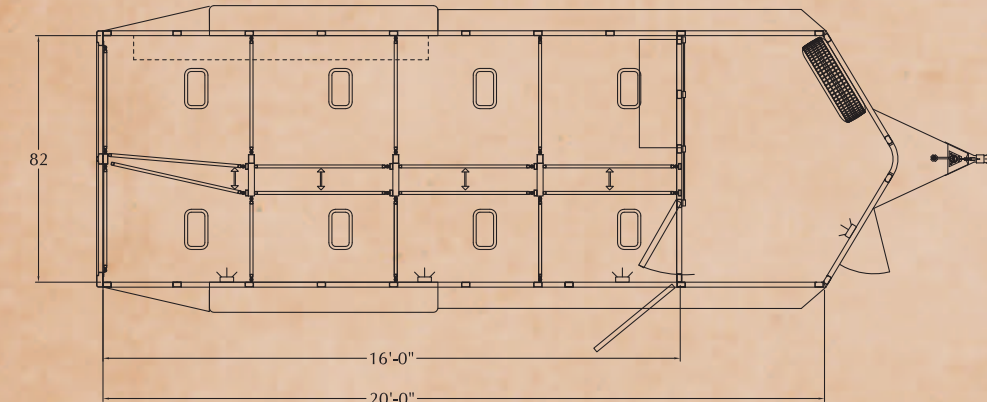
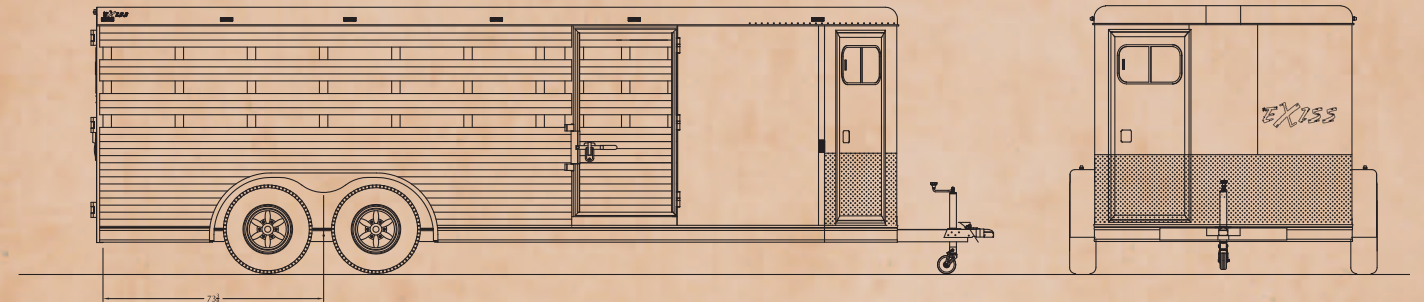

STC 20 BLP
Model Shown

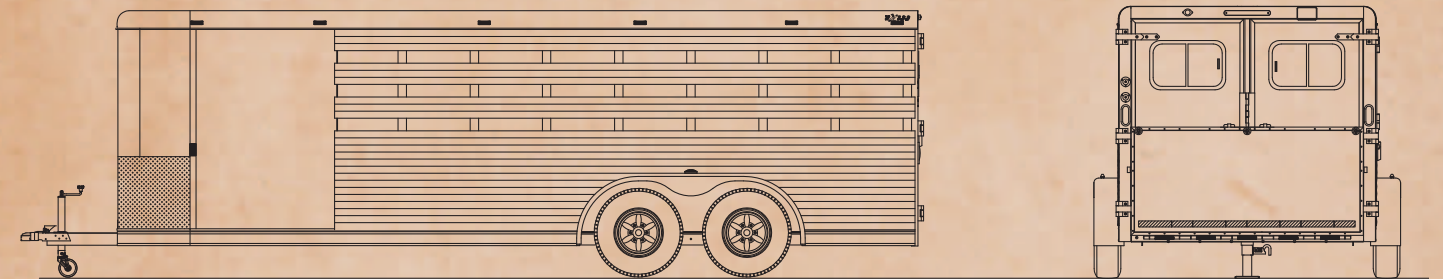

Trailer Model	Belly Length	Interior Height	Outside Width	Dressing Room	Stock Area	Model Style	GVWR	Empty Weight	Wheel Size	Tire Specs	Axle Size
STC 16 BLP	16'	7'	7'	4'	8 Pens	BP	7,000	TBD	15" Aluminum	8 Ply	(2) 5,200
STC 20 BLP	20'	7'	7'	4'	8 Pens	BP	7,000	TBD	15" Aluminum	8 Ply	(2) 5,200

WE STAND BEHIND OUR TRAILERS! To demonstrate our confidence in our trailers, we've increased our warranty coverage! Now, all 2012 trailers come with a fully transferrable, eight-year limited warranty.

38 TRANSFERABLE WARRANTY
3 YEARS LIMITED / 8 YEARS STRUCTURAL



GOOSENECK

7' Wide Models



TRAILER FEATURES

STANDARD FEATURES

- Available in 20' and 24' models
- 6' inside height - 7' outside width
- All-aluminum construction
- Single piece aluminum roof
- Stainless steel nose sheet
- Full length, polished aluminum extruded sides
- Three air gaps and Plexiglas
- Interlocking extruded aluminum plank non-skid floor
- Floor system features 2" X 4" I-beams on 13" centers
- Two 5,200 lbs rubber torsion axles
- Five 15" aluminum wheels with five radial tires
- Two LED tail lights and one large LED clearance light
- 50/50 rear doors with one window per door
- Locking cam latches on livestock area doors

LIVESTOCK AREA FEATURES

- Multiple 4' long pens with divider gates on each side
- Pens convert from 'Alley Way' to '50/50' configuration
- Heavy-duty curbside escape door
- Tray in livestock area for Plexiglas storage
- Heavy duty drop partition with spring loaded latches
- Dome lights with switch recessed in rear frame

DRESSING ROOM FEATURES

- Carpeted dressing room area with 4' straightwall
- One dome light in dressing room
- Clothes rod

POPULAR OPTIONS

- 36" removable shelf in livestock area (14" deep)
- Aluminum pop-up roof vents in stock area
- Full width rear ramp
- 24" walk through door in solid wall
- Built in storage rack for feed pans
- Built in storage bin for whips
- Fold-up step below camper door



In keeping with its policy of continuous improvement, Exiss reserves the right to make specification changes at any time without notice or obligation. All weights and dimensions listed in this brochure are approximate. Illustrations may include optional equipment.

TRAILER SPECIFICATIONS

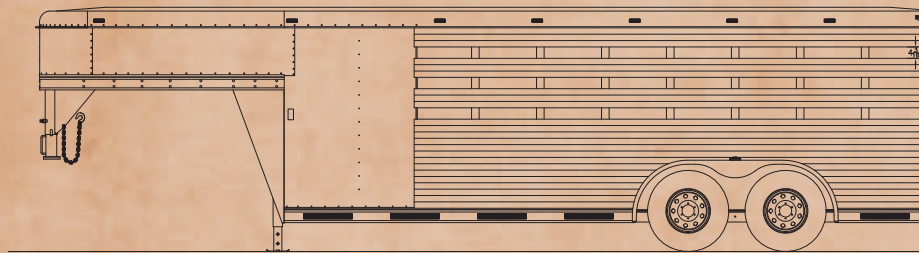
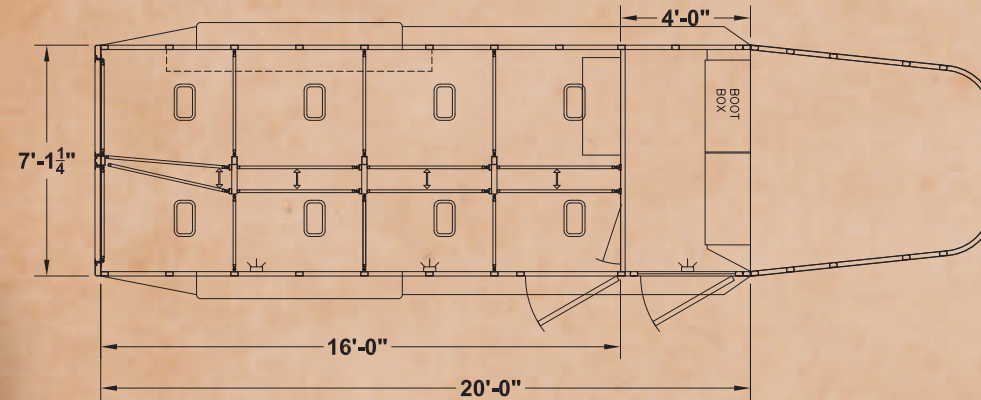
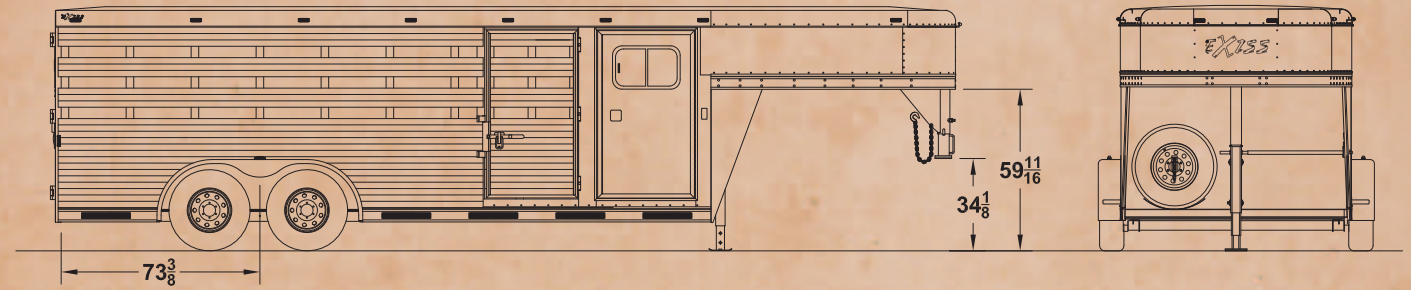

STC 20 LP
Model Shown

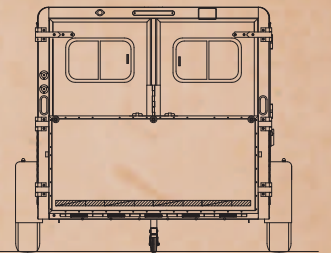

Trailer Model	Belly Length	Interior Height	Outside Width	Dressing Room	Stock Area	Model Style	GVWR	Empty Weight	Wheel Size	Tire Specs	Axle Size
STC LP 20	20'	7'	7'	4'	8 Pens	GN	10,400	TBD	15" Aluminum	8 Ply	(2) 5,200
STC LP 24	24'	7'	7'	4'	10 Pens	GN	10,400	TBD	15" Aluminum	8 Ply	(2) 5,200



CUSTOM MODELS



If you don't see the model that you're interested in, log on to www.exiss.com to inquire about an Exiss custom low profile stock trailer.